

PRODUCT SPECIFICATION

OPTICAL FIBER JOINT ENCLOSURE

INTRODUCTION

LUX's horizontal Optical Fiber Joint Enclosure offers a secure platform for optical splices in vulnerable spot to against outside plant environment.

The fiber joint enclosure is specially designed for harsh environments such as underground, aerial or duct. This optical fiber joint has a large capacity which supports up to 192 core splicing.

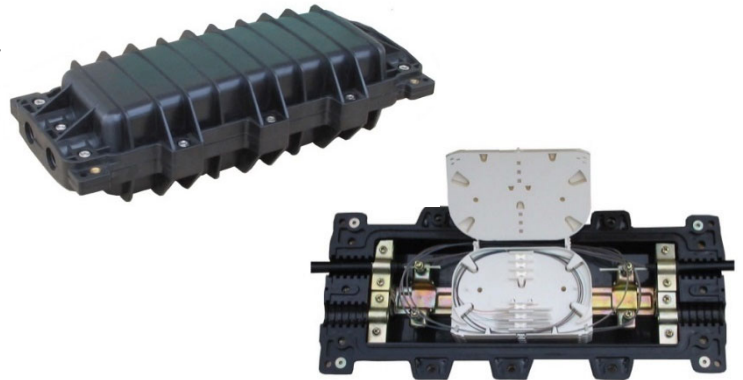

TECHNICAL INFORMATION

Max. Capacity	192 core (Ribbon) 96 core (Single)
Dimension	435(L) x 190(W) x 120(H) mm
Support Cable OD	10mm – 22 mm (2 in 2 out)
IP Rating	IP 65
UV Resistance	UV Resistance
Accessibility	Easy re-accessible

ENVIRONMENTAL PROPERTIES

Storage and shipment temperature:	- 40°C to 70°C
Operating and Installation temperature:	- 40°C to 70°C
Restriction of Hazardous Substances (RoHS) Compliance:	All materials & components meet the requirements of Directive 2002/95/EC.

ORDERING PART NUMBER

Example: FIPFJA-12-BL = 12port Fiber Joint Enclosure

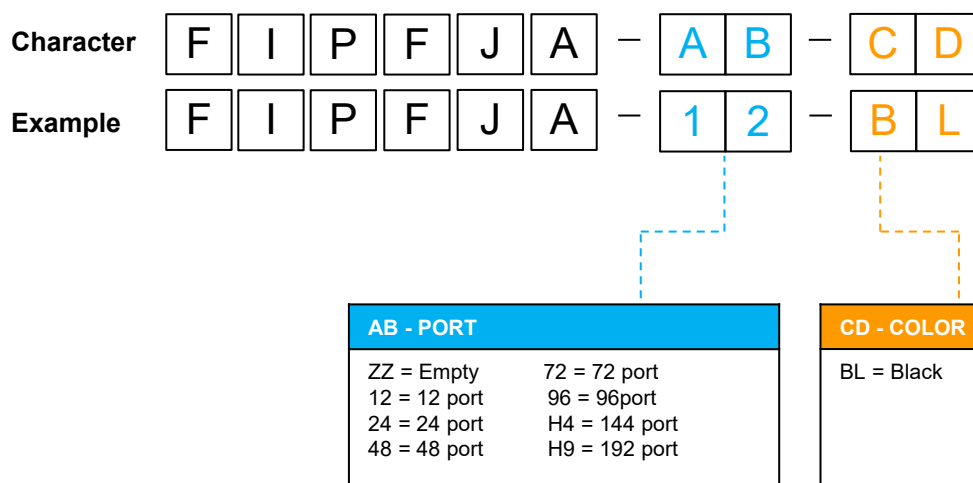

The information and specification in this document are subjected to change without notice